



Agility Dog Show Rule Book



Foreword

This handbook is intended as a guide for 4-H'ers, 4-H leaders, county extension agents, show managers, parents and judges.

This handbook is designed to help establish uniform regulations and procedures for the 4-H dog shows and events throughout the state. Please use this handbook as a guide when setting up your shows and establishing show rules. All judges should be made familiar with 4-H dog show rules and objectives, which often are different than the rules of other organizations.

Objectives

The purpose of the dog project is to help 4-H youth:

- Develop leadership, initiative, self-reliance, sportsmanship and other desirable traits of character.
- Experience the pride and responsibility of being involved with a dog.
- Acquire skill, patience and understanding by training a dog.
- Realize a greater love for animals and a humane attitude toward them.
- Prepare for citizenship responsibilities by working together in groups and supporting community dog projects and activities.

4-H Name and Emblem

The use of the name and emblem of 4-H is regulated by federal law. This law states that only activities or programs under supervision of the Cooperative Extension Service may use the name and emblem of 4-H.

Shows sponsored by other organizations and shows that do not provide separate classes for 4-H'ers are not permitted to use the name and emblem of 4-H. In such cases, the title "junior dog show" or similar name should be used.

Owning a Dog

Because 4-H is a learn-by-doing educational program, it is the intent that 4-H members care for and train their dogs. A member will learn very little if someone else trains and cares for the dog.

Most 4-H'ers will be able to have a dog that they or their family own. Sometimes this is not always possible. Consider these guidelines if you want to have a dog project and you do not own the dog:

1. Member must enroll at appropriate time and carry the dog as a project the entire 4-H year.
2. Member must care for and train the dog. Care includes: feeding, training, exercising, kennel management, grooming, and use of the dog.

3. The club or county 4-H dog leader should be informed of this arrangement at the start of the project.

Agility

Purpose of Agility

The purpose of Kansas 4-H Dog Agility is to provide 4-H'ers the opportunity to demonstrate the teamwork necessary to work under a variety of conditions. By teaching a series of obstacles, the 4-H'er provides the basic training and exercise that leads to a more versatile, well-conditioned dog. The sport of agility provides a basis for other activities such as search and rescue. Agility is exciting for both exhibitors and spectators, as well as motivating for the dogs.

Definition of Agility

Agility is a series of obstacles at three levels of competition: Agility I, Agility II and Agility III. Each level increases in difficulty. Each dog/member team must begin in Agility I and progress toward Agility III.

General Rules

1. State 4-H Dog Show Immunization Record (MG34) should be required at all shows. Proof of rabies vaccination signed by a graduate, licensed veterinarian must be presented to veterinarian or show committee at registration on the day of show to be eligible to compete. Other required vaccinations are: distemper, hepatitis, parvovirus, parainfluenza and bordetella. Other recommended vaccinations are leptospirosis and coronavirus.
2. Any abuse of dogs on the grounds or in the ring will result in disqualification.
3. No dog in season will be allowed to show in agility and must be removed from the show arena grounds immediately.
4. Any dog with a contagious, communicable or infectious disease or condition, in the judgement



of the attending veterinarian or show management, cannot be shown. It must be removed from the show arena grounds immediately.

5. The judge or veterinarian on call has the right and responsibility to excuse any dog he or she considers lame or at risk when participating in agility.
6. Good sportsmanship shall be observed at all times. The judge's decision is final. Poor sportsmanship may lead to loss of ribbon, class dismissal or disqualification from show as determined by judge and show committee. Any protest should be made in writing to the show committee.
7. Dogs and handlers may not enter the show ring before the judge's briefing.
8. Baiting your dog with food or toys will not be allowed.

Non-Qualifying (automatic white ribbon)

Faults:

1. Taking more than the allotted attempts per obstacle (all levels).
2. Failure to attempt an obstacle.
3. Dog fouling ring, except during familiarization.
4. Handler touching obstacle or dog.
5. Three or more obstacles out of sequence.
6. Taking twice as long as maximum course time.

Disqualification (No ribbon)

1. Dogs/handlers dismissed from ring due to:
 - dog leaving ring or out of control
 - dog being overly aggressive
 - dog biting another dog or human
 - handler using abusive language or unsportsmanlike conduct
2. Baiting dog

Ribbons

Ribbons will be awarded as follows:

Purple	190–200 points
Blue	170–189.5 points
Red	150–169.5 points
White	149.5 and less

To earn a state-fair qualifying score the team must pass with a score of 170 points or greater.

Each dog/member team must qualify at the local/county level each year before entering the State 4-H Dog Show.

Agility Advancement

In order to advance from Agility I to Agility II, or from Agility II to Agility III, the team must receive two (2) qualifying scores of 190 points or greater (purple ribbons) under two different Kansas 4-H certified Agility judges at local, multi-county or state competitions. It is suggested that this move be made after the state fair and at the beginning of a new 4-H year.

Handlers With Special Needs

Everything possible should be done to encourage those with special needs to participate. Handlers who are hearing impaired or unable to give verbal commands may use a clicker. In the case of a handler who has a hearing impairment, the judge should use a hand signal to inform him/her of major faults when a repeat attempt is required. It is suggested that one of the timers/stewards maintain a position in front of the handler to relay the hand signal if the judge should fall behind the handler. Handlers may have in-ring assistance when it is needed.

Suggested Classes

All classes will be divided into the three height divisions.

Pre-Agility I is for local shows only and all obstacles will be done on lead. All State Fair agility classes are off lead. It is recommended that pre-novice obedience be a prerequisite to agility training. Dogs should be 6 months or older before agility training begins, but must be 12 months or older to compete.

Jump Heights

Division I	Dogs less than 15 inches at the withers — jump 8 inches
Division II	Dogs 15-20 inches at the withers — jump 12 inches
Division III	Dogs over 20 inches at the withers — jump 16 inches

Standard Course Time

The judge is solely responsible for establishing the standard course time. To determine the course time, it is suggested that the judge walk the course twice and use the average time. Time should be kept to the nearest hundredth (.01) of a second with start and stop when the dog breaks the plane of the start and finish lines.



Agility Classes

All agility classes are off lead. Some local trials may include a Pre-Agility course for on-lead teams. Pre-Agility obstacles would be the same as Agility I.

Agility I (13 obstacles)

Mandatory Obstacles: (7)

A-frame	15 points
Dog walk	15 points
Teeter-totter	15 points
Open tunnel	15 points
Closed (chute) tunnel	15 points
Hoop tunnel	15 points
Pause table	20 points

Optional Obstacles (6)

The following obstacles may be used more than once

Single bar jump	15 points
Bush jump	15 points
High jump	15 points
Log jump	15 points
Picket fence jump	15 points
Lattice fence jump	15 points
Window jump	15 points

Agility II (16 obstacles)

Non-hurdle obstacles

Use all four of the following, plus use one twice:

Crawl tunnel	15 points
Tire jump*	15 points
Weave poles	15 points
Open tunnel	15 points

*While the tire is technically a jump, it is used in Agility II as a non-hurdle obstacle.

Use the following two:

Swing plank	15 points
Sway bridge	15 points

Choice of one of the following two:

Platform jump	15 points
Pause Box	15 points

Jump (hurdle) obstacles (Use 8)

The following obstacles can be used more than once

Single bar jump	10 points
Bush jump	10 points
High jump	10 points
Log jump	10 points
Picket fence jump	10 points
Lattice fence jump	10 points
Window jump	10 points
Broad jump	10 points

Agility III (16 obstacles)

Traps may be included. A trap is any numbered obstacle set in or beside the course path of the dog other than the intended next obstacle. The trap obstacles are positioned parallel to one another with their openings facing the same general direction and must not be closer than 2 feet in the Agility III class.

Mandatory obstacle

Weave poles	15 points
-------------	-----------

Choice of three of six following, or cross-over walk can be used up to three times:

A-frame	15 points
Dog walk	15 points
Teeter-totter	15 points
Cross-over walk	15 points
Swing plank	15 points
Sway bridge	15 points

Choice of three of the following four:

Closed (chute) tunnel	15 points
Crawl tunnel	15 points
Hoop tunnel	15 points
Open tunnel	15 points

Choice of one of the following three:

Platform jump	15 points
Pause box	15 points
Pause table	15 points

Choice of eight of the following eight:

The following obstacles can be used more than once

Single bar jump	10 points
Bush jump	10 points
High jump	10 points
Log jump	10 points
Picket fence jump	10 points
Lattice fence jump	10 points
Window jump	10 points
Broad jump	10 points

Qualification for State Fair

The 4-H'er/dog team must have a qualifying score of 170 points or greater (blue or purple ribbon) at a local or multi-county show during the year at their current agility level to qualify for the State Fair. There is no on-lead (Pre-Agility I) class at the State Fair.



Performance Regulations

Equipment

Dogs must wear a buckle or snap collar with nothing attached during competition. Leads or tabs worn on the familiarization course must be long enough to allow free movement without interfering with the obstacle.

Misbehavior

The sport of agility should be fun for both the dog and the handler and perceived as such.

Any severe disciplining by the handler in the ring, any display of fear or nervousness by the dog, or any uncontrolled behavior of the dog such as snapping, barking, relieving itself in the ring or running away from its handler — whether it occurs during an exercise, between exercises, before or after judging — must be penalized according to the seriousness of the misbehavior. The judge may expel or excuse the dog from further competition.

Familiarization Course — All Levels

The judge will meet with handlers for the “Judge’s Briefing.” Immediately following the briefing, the handlers may walk the course (without dogs) and ask questions. This period of course orientation is followed immediately with the “on-lead walk through,” except that there shall be no on-lead walk through for the AGIII class.

The purpose of this type of on-lead walk through is to allow the handler to become familiar with the course and for the dog to become familiar with the obstacles being used that day. The familiarization course is to provide the dog an opportunity to go over, under or through the obstacles used before the performance. It is NOT to be used as a training session. Therefore, **ONLY ONE ATTEMPT** is allowed for each obstacle.

Anyone absent during the briefing and walk through will forfeit their opportunity. It is NOT required to take the dog through the familiarization course. The handler may choose not to do all of the obstacles during the walk-through.

All dogs are required to be on a lead as they go through the familiarization course. A short lead is recommended. The length of the lead will depend on the size of the dog. It should be long enough to allow the dog to move freely, but not so long as to wrap around the obstacles when released. The handler must keep hold of the lead at all times, except when it has to be released for the dog to execute an obstacle. When the dog has executed the obstacle,

the handler must again pick up the lead.

On the on-lead walk-through, if there is any training in the ring, including more than one attempt of an obstacle, the team will be charged with a minor fault (2 points) that will be assessed toward their final score. If the dog fouls the ring during the on-lead walk-through, the team will receive a major fault of 10 points against their actual run.

Warm-Up Area

A warm-up area consisting of two single bar jumps is recommended. Each team will be allowed up to two warm-up runs just before entering the ring.

Obstacle Spacing

A non-skid surface should be used on the floor when doing agility indoors.

All obstacles should be placed in a way that large dogs can maneuver into position for a proper approach to each obstacle.

Two obstacles sitting side-by-side and facing the same direction should not be closer than 10 feet in Agility I, 6 feet in Agility II and 2 feet in Agility III.

There should be at least 10 to 15 feet separating any two non-hurdle obstacles.

There should be at least 15 to 18 feet separating any two hurdle obstacles.

Forcing dogs to jump with a space constraint can result in injuries. Total ring size should be at least 5,000 square feet.

Agility Scoring

Scoring is determined by deducting all of the running, handler and time fault points from the total course value of 200 points. The actual time is used only to break ties. The number of obstacles in a course does not matter. The maximum penalty points per obstacle are given with the obstacle list for each level.

In Agility I and II, when a major fault occurs that is not obvious to the handler, the judge will call “fault.” The handler will be assessed a failed attempt and must repeat the obstacle. If the handler does not repeat the obstacle when a major fault occurs, it will be scored as an unsuccessful completion of the obstacle, and the handler will lose the full amount of points for that obstacle.

Three attempts to complete an obstacle are allowed in Agility I with a loss of 5 points on each attempt. Agility II allows two attempts per obstacle with 5 points for the obstacle taken off for the first failed attempt, and the remaining points for the obstacle taken off for the second failed attempt. One



failed attempt in Agility III will be a loss of all points for the obstacle.

General Minor Faults (-2 points)

1. Running by an obstacle.
2. Nicking a jump with toenails or other body parts.
3. Crooked approach or leave on contact obstacles.
4. Hesitation to do an obstacle.
5. Doing obstacles out of sequence (minor faults will often occur both for the run by and also for out of sequence).
6. Dog nipping at handler.

General Major Faults (-5 points)

1. Failed attempt (5 points for AGI and first attempt in AGII; remaining points on second failed attempt in AGII and all points for obstacle in AGIII).
2. Missing a contact zone (at least one paw must touch).
3. Displaced bar on a jump.
4. Leaving pause table/box without sitting or lying down.
5. Failure to enter weave poles on left side of dog.
6. Handler breaking plane of obstacle, except for exit ramp of A-frame.
7. Handler intentionally blocking forward progress of dog.
8. Handler jumping any obstacle.
9. Dog bailing from the teeter (leaves before teeter touches ground).
10. Stepping over the 2-foot guideline on weave poles, pause box, or table and platform jump.

Running Time Faults

1. One point is deducted for each second over the standard course time.
2. Time should be rounded down to the nearest full second for penalty point determination.

Obstacle Scoring

Dog Walk and Cross-Over Walk

Major Faults: The dog must place at least one foot on or below the contact line when entering the obstacle on the approach ramp and must place at least one foot on or below the contact line on the off ramp. Exiting off the wrong ramp is a major fault for the cross-over walk.

Minor Faults: The walks should be entered straight from the previous obstacle and the exit should be straight to the next obstacle. This should be done with confidence and without loss of atten-

tion by pausing or hesitating along the way, with the exception of a pause for exit instructions on the cross-over walk.

A-Frame

Major Faults: The dog must place at least one foot on or below the contact line on the off ramp. The contact line on the entrance side of the A-frame is not judged.

Minor Faults: The A-frame should be entered straight from the previous obstacle and the exit should be straight to the next obstacle. The A-frame is unique in that the handler may use his/her hands and body to prevent the dog from jumping or falling off the exit ramp of the A-frame. This is allowed to help prevent the possible occurrence of injury. Short of the handler getting his/her hand to within a couple of inches of the dog or actually touching the dog, no fault should be deducted.

Open Tunnel

Major Faults: A major fault occurs when any part of the front of the dog breaks the plane of the opening during an attempt to enter the tunnel, and the dog backs away and does not complete the attempt.

Minor Faults: Since the dog cannot be seen, considerable allowance should be made for the dog to complete the obstacle before any deductions are made.

Closed Tunnel

Major Faults: A major fault occurs when any part of the front of the dog breaks the plane of the opening during an attempt to enter the tunnel, and the dog backs away and does not complete the attempt. If a dog attempts to exit through the side of the tunnel, a major fault is assessed.

Minor Faults: If the dog pauses in the tunnel, a deduction should not be made unless the pause becomes prolonged or the dog begins to move around as though it might be trying to get out without continuing to the end of the cover.

Hoop Tunnel

Major Faults: The most frequently committed fault occurs when the dog exits the obstacle between two of the hoops, rather than continuing all the way through. Another common fault occurs when the dog starts to enter between two hoops along the side rather than through the first hoop at the end. Either of these is a major fault resulting in a failed attempt.

Teeter-Totter

Major Faults: The dog must place at least one foot on or below the contact line when entering the



teeter-totter on the approach ramp and must place at least one foot on or below the contact line on the off ramp; the teeter must touch the ground before the dog exits the teeter.

Minor Faults: The teeter-totter should be entered straight from the previous obstacle and the exit should be straight to the next obstacle. A fast exit, causing ramp to “bang” on the floor, is a minor fault.

Pause Box/Pause Table

In Agility I and II, the handler must indicate to the judge whether the dog will sit or down on the table in I and the box in II. In Agility III, the judge chooses sit or down and box or table. In case of a fault on the sit or the down, the 5-second count should be restarted.

Major Faults: If the dog enters the box/table and then exits the obstacle without completing the exercise, this is considered a major fault. If the dog is laying or sitting in the pause box, and a foot or leg rests on the box itself, no penalty should be made. However, if the leg goes over the side and touches the floor, this is a major fault.

The pause obstacle chosen for AGIII (pause box, table or platform jump) shall have a mark or line drawn two feet from all four sides (unless a side is near a wall or fence) as a reference guide for the handlers. The handler cannot step over the line or he or she will be assessed a handler error equal to a major deduction of -5 points each time. The handler can cross over the line with a hand as long as he or she does not cross the plane of the obstacle.

Minor Faults: Breaking the sit/down is a minor fault. A minor deduction should be assessed if the handler has difficulty getting the dog to sit or down. Entry must be made on the side directly facing the previous obstacle. Exiting also must be made from the side facing the next obstacle.

Jump Obstacles (Single Bar Jump, Bush Jump, High Jump, Log Jump, Picket Fence Jump, Lattice Fence Jump, Window Jump, Broad Jump, Tire Jump)

Major Faults: A major fault occurs when a dog places at least one foot on any part of the jump and then backs away. As with any obstacle, if the dog stops and refuses to negotiate the obstacle, it is a major fault, and if the dog continues to refuse, the full value of the obstacle must be deducted and recorded as incomplete. If the dog goes between the tire and the uprights of the tire jump, it is a major fault. If the obstacle is knocked over or displaced by

the dog, all points are deducted. If the obstacle is to be repeated later in the course, the obstacle cannot be reset and will have to be scored as incomplete and all points are deducted.

Minor Faults: Running past the end of the jump or pausing in front of it and showing a reluctance to jump are considered minor faults. Nicking a jump with toe nails or other body parts is considered a minor fault.

Sway Bridge

Major Faults: The dog must place at least one foot on the approach ramp when entering the sway bridge and must place at least one foot on the off ramp when exiting the sway bridge. The dog must place all four feet on the sway portion of the bridge as the dog is moving across. Failure to do this is a major fault. Because this is not an “obvious” fault, the judge must call out the word “Fault.”

Minor Faults: The sway bridge should be entered straight from the previous obstacle and the exit should be straight to the next obstacle.

Crawl Tunnel

Major Faults: If a dog attempts to exit through the side of the tunnel, a major deduction is made.

Minor Faults: A minor deduction is made for raising the obstacle off the ground but not overturning it. Crawl spaces are to be set at 8, 12 and 16 inches for Division I, II and III respectively. The following accommodations will be made for deep-chested dogs: a Division I dog with depth of chest up to and including 7 inches would crawl at 8 inches; over 7–10 inches would crawl at 12 inches. A Division II dog with a depth of chest between 7–10 inches would crawl at 12 inches and over 10–14 inches would crawl at 16 inches; a Division III dog with a depth of chest at over 10–14 inches would crawl at 16 inches and over 14 inches would crawl at 20 inches.

The depth of chest of a dog is measured by placing the dog in a down position and measuring from the floor to the point of the shoulders (withers).

Platform Jump

Major Faults: To successfully complete the platform jump, the dog must step on to the first platform from any side except the side next to the bar jump, then sit, then hop or jump over the bar jump and then again sit before stepping off the second platform on any side except the side next to the bar jump. The approach to the platform jump is an exception to the normal entry of obstacles in that it can be entered from three different directions.



Failure to accomplish any part of this in the exact sequence as stated results in a failed attempt. Failed attempts include: the dog places at least one foot on the platform and withdraws it; the dog steps off the platform, even with only one foot, before jumping the bar; the dog jumps the bar without first sitting, or after jumping the bar, the dog steps off the second platform without first sitting.

Minor Faults: Minor faults may be made for difficulty or slowness in sitting, or for showing a reluctance to jump the bar.

Swing Plank

Major Faults: The dog must enter or step on the swinging plank from the end facing the previous obstacle. If the dog jumps across the platform from any side, it is a major fault. In crossing the plank, the dog must place each of its four feet on the plank. Failure to do this is a major fault, and the judge must call out "Fault."

Weave poles

The judge should place a mark or line 2 feet from the center line of the poles as a delimiting line for the handlers. The handler cannot step over this line or he or she will be assessed a handler error equal to a major deduction of -5 points each time. The handler can cross over the line with a hand as long as he or she does not cross the plane of the weave poles.

Major Faults: The dog must enter the poles with the first pole on the dog's left side. Any other entry is a major fault. Any time the dog enters or breaks the plane between two poles out of sequence, a major fault must be assessed. Major faults also may occur if the handler in any way blocks the dog or uses excessive directions to get the dog to move in and out through the sequence of poles.

Minor Faults: A minor fault occurs when the dog goes past a pole before backing up to go between

that pole and the previous pole in proper sequence. This fault is similar in concept to running past the opening to a tunnel or the front end of a ramp.

Broad Jump

Major Faults: Failure to clear the obstacle, or walking over any part, results in a failed attempt.

Minor Faults: Minor points should be deducted if the dog clicks the jump with its toenails.

Stewards:

The following stewards are recommended for an agility competition. All in-ring stewards will be responsible for equipment changes. Record handler's choice of sit or down for pause table/box for Agility I and II at check-in.

Gate/Table (at least two stewards, three is preferable): Responsibilities include the check in of participants, calling participants for their run, adding score sheets and putting ribbons with the score sheets.

Warm-Up Area: Responsible for supervising the warm-up area. Each participant will be limited to two runs (one steward).

Time Keepers (two stewards): In charge of timing each participant's run. The time starts when the dog breaks the plane of the start line and ends when the dog breaks the plane of the finish line. **Note:** If electronic timing is used, the time starts when the dog trips the timer on and ends when the dog breaks the electronic beam at the finish line.

Pause Table/Box: May act as a counter for the sit or down on the pause table/box. The counter will count "1-2-3-4-GO" while extending his/her arm in a counting motion. This function is normally done by the judge.

Obstacle (two stewards): A steward may stand in close proximity to the A-frame, teeter-totter and dog walk without interfering with the dog or handler. During the judge's briefing, the judge will indicate where the obstacle stewards will stand.



Specifications for Construction of the Agility Obstacles

General Considerations

Materials used in the construction of agility obstacles may include wood, metal and PVC. Obstacles should be painted for easy visibility. The use of bright colors and decorative attachments (i.e. wings or potted plants) with certain obstacles is left to the imagination of the sponsoring clubs. The appearance and construction of the attachments must be approved by the judge to assure that they are safe and will not interfere with the performance of the dogs and handlers. Specifications in these regulations have been modified, in some cases, so that the same obstacle approved for use at U.K.C. trials, may also be used in other agility programs.

Many of the obstacles are constructed wholly, or in part of PVC pipe and fixtures. Usually, the outside diameter of the pipe is different from what it is referred to by the manufacturer: 2-inch pipe is actually $2\frac{3}{8}$ inches, 1½-inch is actually $1\frac{7}{8}$ inches, 1-inch is actually $1\frac{1}{8}$ inches, ½-inch is actually $\frac{3}{4}$ -inch. (These measurements refer to the outside diameter of the pipe.) In almost all cases, Schedule 40 thick wall PVC is used; the crawl tunnel requires Schedule 40 or 80 thick wall PVC pipe.

Surface Preparation.

Surfaces that dogs walk on must be of a non-skid material. Several commercial coatings such as those formulated for use on boat decks, tennis courts, etc., are available from paint stores. Similar surfaces may be obtained by using a paint additive (perlite or sand) to regular exterior paint. Perlite is available at paint stores or garden stores, where it is sold as an additive to plant potting soil. However, this type has large pieces, requiring it to be screened so that only the smallest particles are used. Regular window screen is satisfactory for this purpose. The perlite may be added directly to the paint before being applied, or a small area may be painted and the perlite sifted over the wet paint with a shaker can. A second coat of paint is then applied. When using sand, it should be sifted over the wet paint as described for perlite.

Surfaces on newly constructed dog walk, teeter-totter, A-frame, sway bridge and cross-over walk obstacles must have non-skid surfaces as described above.

Ramps and panels of the contact obstacles (dog walk, teeter-totter and A-frame) may be painted the

same overall color. The contact zone may be painted a contrasting color from the upper sections of the ramps or panels. However, none of the surfaces that the dogs must walk may be painted white, brown or black. In either case, it is strongly recommended that a 1½- to 3-inch contact line of a contrasting color be used. The colors must extend around the sides (edges) of the panels so that the contact line can be easily seen from a side view.

Cleats (cross pieces, slats) are required only on the A-frame, but may be used on the teeter-totter and dog walk. When attaching the cleats to the ramps or panels, the first cleat should be positioned in the location of the contact line: the upper edge of the cleat is placed along the upper edge of the contact line. The remaining cleats are then attached at appropriate distances from that first one, serving as the contact line. Cleats serving as contact lines are painted a contrasting color, as would be the contact line. All other cleats are to be painted the same color as the panels or ramps they are attached to.

When constructing new obstacles with cleats, the cleats could be made from door frame molding sold at lumber yards. This molding is about $\frac{3}{8}$ inch thick by 1½ inches wide, and must be cut to extend to within ¼ inch of the sides of the ramps. The purpose of this size and type of cleat is to prevent possible injury to the feet of large dogs that may land on the edges of the thicker ¾-inch wooden cleats previously used.

If PVC obstacles will have long exposure to direct sunlight, they should be painted to prevent ultraviolet light from causing the plastic to harden and crack. Furniture grade PVC has an additive that protects from UV radiation.

Agility I Mandatory Obstacles

(1) A-Frame

This obstacle consists of two panels connected along their narrow edges and positioned to form a structure similar to an A-frame. The dogs must climb up one side, go over the top and down the opposite side.

Each panel (ramp) may be either approximately 6 feet, 8 inches, or 8 feet long, and 30 to 48 inches wide. This allows for the use of standard hollow core doors purchased from a lumber store or 4-by-8-foot sheets of plywood. When a plywood surface is used, a sturdy wooden or metal framework must be built



and attached to the plywood. The panels must be rigid enough to withstand the impact of large dogs jumping part way up onto the panels.

The two panels are hinged at the apex when positioned for use. Heavy door hinges may be used for this purpose. A separate wooden piece must be used to cover any gap between the two panels at the apex to prevent dogs from getting a foot caught between the panels. A chain is attached at the base, or halfway up on the inside of each panel to provide the proper angle to the panels, and to keep them from slipping apart when set up for use. The 6-foot- 8-inch-panel A-frame, or the 8-foot-panel A-frame is each set up with the apex 48 inches above ground. In both panel lengths, the top edge of the contact line is located 40 to 42 inches from the bottom edge of the panel.

Wooden cleats (cross pieces or slats), approximately $\frac{3}{8}$ inches thick by $1\frac{1}{2}$ inches wide and cut to extend the width of the panels, are attached so that the top edges of the cross cleats are 7 to 12 inches apart. It is preferred to have a cleat serve as the contact line, but is not required.

(2) Dog Walk

This obstacle consists of a horizontal plank approximately 3 feet high, with a similar ramp leading up to the horizontal plank, and another ramp leading down from the horizontal plank. Each ramp has contact lines.

The two ramps and horizontal plank are 12 inches wide (tolerance $\frac{1}{2}$ inch). Each ramp is about 8 feet long, but may be up to 3 inches less than 8 feet, to fit into an 8-foot trailer for storage and transportation.

All three planks may be made from solid dimensional lumber (2-by-12-inch), or constructed as hollow core planks. If the solid lumber is less than $11\frac{1}{4}$ inches wide, a narrow strip of wood must be attached along the side(s) of the boards to increase to the required width.

Hollow-core planks are easily made and have many advantages over solid lumber: they are much lighter and do not tend to warp out of shape. If the dog walk and teeter-totter are constructed at the same time, the eight pieces of plywood required for the upper and lower surfaces of the four planks (three for the dog walk and one for the teeter-totter) may be cut from two 4-by-8-foot sheets of $\frac{1}{4}$ -inch plywood (each plank is 12 inches wide). Solid 2-by-2-inch lumber is glued and nailed along the sides of three of the 8-foot-by-12-inch sections cut from the $\frac{1}{4}$ -inch plywood. The 2-by-2-inch pieces must

extend the full length of the plywood in order that the fixtures used to attach the ramps to the horizontal plank are best secured. Lengths of 2-by-2-inch boards (about 8 inches each) are then fixed in place at each end between the 8-foot side pieces. Measure and cut these end pieces after the side pieces have been fixed in place, as the exact length of the end pieces will depend on the exact width of the 2-by-2-inch side pieces.

Strips of rigid Styrofoam cut to the thickness of the 2-by-2-inch side and end pieces are placed on the inside to support the center of the plywood surfaces. The strips of Styrofoam are glued in place along the center of the space between the two side pieces; the Styrofoam does not need to fill the entire center space. A second piece of plywood is then glued and nailed over the top to form the top surface of the plank.

The surfaces of the planks are to be finished with non-skid paint as described earlier. Cleats (cross slats) are not required, but if used, they should be made of the same door frame molding as described earlier.

The contact area is 48 inches from the bottom edge on the up and down planks (ramps). If cleats are used for traction, one should be placed at the 48-inch line perpendicular to the plank with the others at regular intervals along the plank. Paint the contact area a color that sharply contrasts with the colors used for the top sections of the planks/ramps.

The support legs must be tall enough to raise the horizontal plank to a height of about 36 inches. The legs may be constructed of steel pipe, square steel tubing, PVC pipe or wood. The construction must minimize any movement of the planks.

The attachment of the ramps to the horizontal plank may be done in a variety of ways; for example: heavy door hinges or specially made hooks attached on one end of the ramp that fits into holes of brackets attached to the end of the horizontal plank. In any case, gaps between the ramps and the horizontal plank must be such as to not allow a dog to catch a foot or toenail.

(3) Teeter-Totter

Dimensions of the teeter board may be either 8, 10 or 12 feet long and 12 inches wide (with a $\frac{3}{4}$ -inch tolerance). The length of the 8-foot board may be as much as 3 inches less than 8 feet for transportation purposes. The teeter board may be made of solid wood or it may be of hollow core construction. For directions for building hollow core planks, see (2) Dog Walk.



Paint the surface of the teeter board with a non-skid material. Cross slats are not required or recommended. However, if they are used, we suggest the use of door frame molding that is 2 inches wide and ½ inch thick along one side, tapering to about ¼ inch thick along the other side.

The surface of the board may be painted in several ways. When cross slats are used, the entire surface of the teeter board may be painted the same color with a 2- to 3-inch contact line painted with the top edge (edge toward the center of the board) 24 inches (tolerance ¾ inch) from the end of the board. The 24-inch specification is the same for either the 8-, 10- or 12-foot teeter boards. The contact line must be painted a contrasting color. If slats are used, it is strongly recommended that a slat be placed in the exact position of the contact line and painted a contrasting color. The color of the contact line is to be extended around the edges of the board, so that the contact line may be seen from the side.

The teeter board is supported on a steel, PVC or wooden base that allows the board to pivot freely at the center point. The board is attached to the base by means of brackets through which a pivot rod is inserted. **The pivot rod for the 8-foot teeter board is set so that the surface of the board at the pivot point is 16 inches above ground. The 10-foot board is set with the pivot point 20 inches above ground, and the 12-foot teeter board is set with the pivot point 24 inches above ground.** These dimensions provide for an angle of incline of about 20 degrees. One end of the board is to be weighted so that following the exit of a dog, the board will return to its original position with the entrance end down. The teeter board can also be set off center to achieve the weighted end.

(4) Open Tunnel

When set up, the tunnel must have a bend or a curved shape so that when entering, the dog cannot see the opening at the exit end. Two designs may be used for the open tunnel that satisfy that requirement.

Model 1. This design consists of a cylindrical tube formed from a coil of heavy wire covered with a heavy material, such as canvas. The tunnel may be lengthened or shortened, and curved in various ways. The overall length when expanded should be about 15 to 20 feet. The diameter of the opening should be about 24 inches. In order to keep the cylindrical tunnel from rolling out of place or pulling together when in use, a metal or wooden structure, or a strap or bungee cord placed over the top and secured to sand bags on each side may be used.

This style tunnel may be purchased from several different companies that manufacture agility obstacles.

Model 2. This design uses a wooden base constructed in a manner similar to that described for the closed tunnel. The base consists of two sections of ¼-inch plywood, each 16 inches wide and 8 feet long. A corner is cut from one end of each of the two 8-foot sections at an angle of about 30 degrees (the cut is made so that one side of the base board is 8 feet, while the other is 7 feet, 7½ inches). This is done so that when the two sections are placed end to end at the edges of the angled cuts, the tunnel has an approximate 30-degree angle midway along its 16-foot length.

The edges of the plywood are reinforced with 2-by-2-inch wood pieces cut to the proper length. Before attaching the 2-by-2-inch pieces, eight matching pairs of ¼-inch holes are drilled through them (four holes in each board) as described for the closed tunnel. The pairs of holes used to hold the wickets are approximately 2 feet apart. Because of the angled cuts on each of the bases, the wickets at the cut ends will be at an angle parallel to the cut edges. Details of the construction of the bases may be found under the description of the closed tunnel. Eight wickets of the same type and size as the two used in the closed tunnel described above, are needed to support the cloth cover of the tunnel.

The cloth cover is made most easily in two sections. Cloth material needed to cover the first 8-foot base section is about 93 inches by 72 inches wide. Three-inch headings are sewn in each end, providing a total finished length of about 87 inches. The wickets for each end of the first section of the base are inserted through the headings of the cloth cover, while the two center wickets are put in place on the wooden base. The cloth cover is then draped over the two center wickets and the two end wickets and placed at the ends of the base to hold the cloth cover in position.

Cloth needed to cover the second section must be about 115 inches long. A 3-inch heading is sewn in one end of the cloth, while the other end is simply hemmed. One of the wickets for this section is inserted through the heading, while the other three wickets are put in place on the wooden base. The cloth cover is then draped over the other three wickets, and the one end wicket that had been inserted through the heading of the cloth cover is inserted in place in the wooden base. This second section of the cloth cover must be put in place after the first section so that about 18 inches of this second section



will overlap the first section. When each section of the cover is tied down along the sides as described for the closed tunnel, the second section will remain in place. When the cover is made in two sections as described, it does not have to be sewn to fit around the angle in the tunnel base.

If the open and closed tunnels are made at the same time, the three base boards may be cut from a single 4-by-8-foot sheet of $\frac{1}{4}$ -inch plywood.

(5) Closed (Chute) Tunnel

This obstacle consists of a short open section that is attached to a collapsed cloth tunnel through which the dog must push its way through to the outside. Two different designs may be used in the construction of the closed tunnel.

Model 1. In this design, a plastic barrel (may be obtained from car washes) or an open-ended box constructed from wood, is used to serve as the opening into the closed portion of the tunnel. The opening into the barrel must be at least 24 inches in diameter (or 24 inches square) and should be 24 to 36 inches long. The barrel must have a base or braces (sand bags may be used) to keep it from moving out of position. The inside bottom of the barrel or wooden structure must be painted with nonslip paint or have non-slip tape (such as is used in bath tubs) to provide good footing for the dogs. Also, if the edges of the barrel are sharp, resulting from cutting out the bottom (or top) of the barrel, rubber padding must be taped or glued to the sharp edge to prevent injuring a dog. Rubberized pipe insulation works well for this purpose.

The collapsed or closed portion of the tunnel may be made from various types of material, such as rip-stop, parachute material or other types of cloth that are not too heavy or bulky for the very small breeds to push through. It must be a dark color to prevent light from entering and 6 to 10 feet long (overall length of the open and closed portions is 9 to 13 feet). The cloth is sewn into a tapered tube that fits around the barrel on one end and expands to at least 86 inches in circumference on the other (exit) end.

Model 2. In this design, there is a wooden base with a cloth cover over the entire tunnel. The opening into the tunnel is formed by two wickets, about 2 feet apart, located at one end of the base. The cloth cover is placed over the wickets and then extended over the remainder of the wooden base.

The wooden base, 2 to 3 feet long, is made from $\frac{1}{4}$ -inch plywood cut to 16 inches wide, with 2-by-2-inch boards attached along each edge.

Before attaching the 2-by-2-inch boards along the sides of the $\frac{1}{4}$ -inch plywood, two pairs of holes are drilled through the 2-by-2-inch boards: the first pair is 2 inches from the end of each 2-by-2-inch board, and the second pair is 26 to 32 inches from the same end. These are used to hold two wickets that form the opening to the tunnel. The wickets are made from $\frac{1}{4}$ -inch steel rod. The sides (uprights) of the wickets are 28 inches, and the cross piece is 14 inches. The total length of $\frac{1}{4}$ -inch rod needed for one wicket is 70 inches.

The cover must be a dark color and lightweight enough to allow small dogs to push their way through. A piece 13 to 14 feet long and 72 inches wide is required. A heading is sewn in one end of the cloth that the first rod wicket is inserted into before inserting the ends in the first pair of holes on the wooden base. The second wicket is put in place, and the cloth is draped over and extended out over the wooden base. Grommets or strap loops are fixed at 2-foot intervals along the sides of the cloth cover. Matching 12- to 16-inch lengths of cord are stapled (at their middle) to the sides of the wooden base. These are tied through the loops to hold the cover down along the sides.

(6) Hoop Tunnel

This obstacle consists of eight hoops about 30 inches in diameter that are held in place by a PVC pipe framework. They are set at alternating angles of about 60 degrees to one another, to form a zig-zag pattern when seen from above. The dog must move through all eight of the hoops with the bottom of the hoops about 1 inch above the ground.

The 30-inch hoops may be made of $\frac{3}{4}$ -inch (or 1-inch) black plastic underground water pipe that is sold in coils at most hardware and garden stores. Since the pipe comes in coils, it is easiest to form the proper size hoop by measuring its diameter while still in the coil and then cutting the hoop from the coil. Connectors for this type of pipe may be purchased with the pipe to attach the two ends of the cut piece to make a hoop.

The framework is constructed from 1-inch Schedule 40 (thick wall) PVC pipe. There are two base runners: one with four uprights and one with five uprights. The uprights are 32 inches high and are spaced 30 inches apart on each runner. The two sections of runners and uprights are held in a vertical position by cross pieces of PVC pipe, 30 inches long, that connect the upper ends of four of the uprights of one section to the tops of four uprights of the other

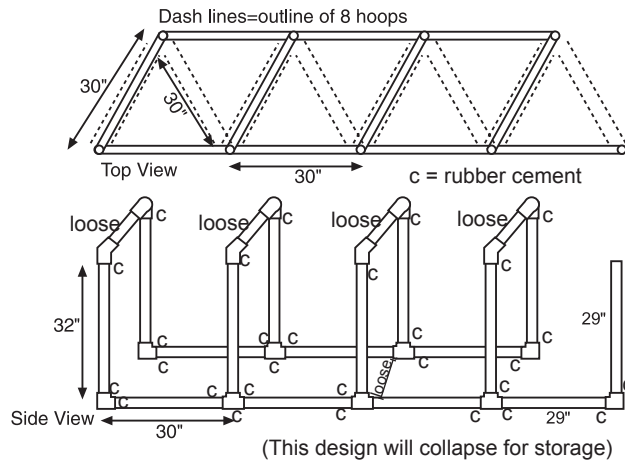

section; one upright on the 5-upright section will be free standing. In this way, the two sections of uprights and runners are about 24 inches apart.

When assembling the obstacle, the uprights of the short section (with four uprights) are positioned so that the uprights are directly across from the midpoint of the space between two uprights of the long section with five uprights. When each hoop is attached to a pole on each side, the hoops form a zig-zag pattern as seen from above.

The hoops are attached so that they are about 1 inch above ground. No adjustments in the height of the hoops from the ground are made for the three size divisions.

The hoops are easily attached and released from the uprights with flat elastic bands (obtained at fabric stores) about 15 inches long. Several overlapping wraps of the elastic hold the first end in place. Then the free end is tucked under the outside wrap to hold the second end in place. If a loop formed near the end is tucked under with the actual end of the elastic sticking out, that end can be pulled to release the elastic.

(7) Pause Table

The table top must be about 3 to 3 1/2 feet square and must be covered with a non-skid surface. The same non-skid surfaces used for the A-frame, dog walk, teeter totter, etc should be used.

Provisions must be made for adjusting the height of the table to 8, 12 and 16 inches. This may be done most conveniently by constructing the legs or table support as solid box-like structures in three sections. The first section with the top surface must be 8 inches high (including the top surface) for use when judging the Division I dogs. The other two sections are each exactly 4 inches high. Wooden blocks, about 3 inches long, are attached at the inside of each corner so that each block extends about

1 inch past the edge of the 4-inch sides. These allow the sections to be stacked and not slip apart. The first 8-inch section and one of the 4-inch sections stacked below it makes the 12-inch table. All three sections make the 16-inch table.

Agility I Optional Obstacles

Jump Obstacles — General

Construction of the jump obstacles may be of PVC, wood or combinations of these and other materials. PVC pipe is perhaps the most desirable for ease of construction, light weight and easy disassembly for storage and transportation. In most cases, Schedule 40 (thick wall), 1½-inch PVC pipe is used.

All jumps must have a jump space over the jumps of between 3½ to 4 feet wide. The uprights that define the jump space must be 3 to 4 feet high to define the area above the jumps through which the dogs must jump. Those such as the bush, log and long jumps do not have uprights as a normal part of their construction; therefore, separate uprights must be used with each of those jumps. Separate uprights need be nothing more than proper lengths of PVC pipe supported by PVC or wooden bases. As with any of the obstacles, the jumps may be painted in bright colors. **The top surface over which the dog actually jumps should be painted with stripes or contrasting colors to clearly distinguish and make visible that portion of the jump to the dog.**

In some of the jump obstacles, the uprights may be separate, supported on their own bases. In others, they may be connected by a cross piece that extends from the base of one upright to the base of the other at ground level.

All of the jumps except the broad jump may be jumped from either side.

(1) Single Bar Jump

This jump has only one displaceable bar that is moved to serve for all three jump heights. The uprights and bar may be constructed of 1½-inch Schedule 40 PVC pipe or wood, and should resemble the bar jump used in obedience. The height of the uprights is 3 to 4 feet.

The displaceable bar is held on the uprights by pins through the uprights, or by cup-like supports attached to the inside of the uprights. The cupped supports must be shallow enough to allow for the easy displacement of the bar. When pins are used to hold the bar, and the jump must be jumped from both sides in a given course design, the pins must be inserted from opposite sides of the two uprights

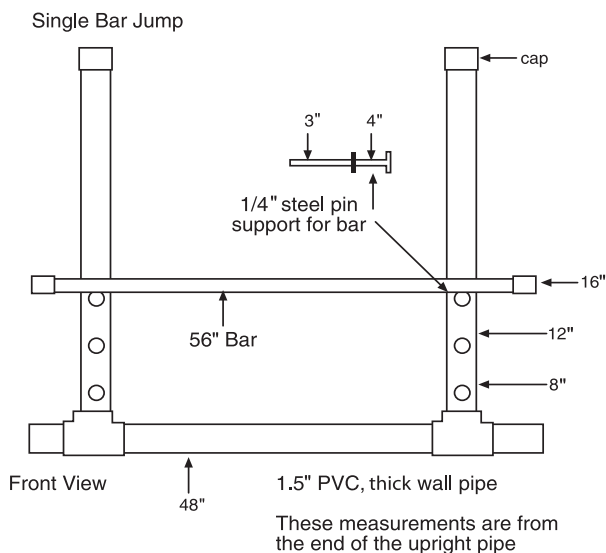

Note: The holes for the 1/4" steel pins will be drilled to allow for the 56" bar to be set with the top to be 8", 12" and 16" from the floor

so that the bar is crossed from one side of one upright to the opposite of the other upright. This will allow for the easy displacement of the bar from either side of the jump.

(2) Bush Jump

This jump must be constructed in such a way as to hold live plants, branches cut from leafy shrubs or plastic decorative plants. Tips of the plants must reach about 8, 12 and 16 inches for Divisions I, II and III, respectively.

Various types of designs are acceptable. One design uses a wooden "planter box" that holds the plants, the total height being 8 inches. Two other box frames, each 4 inches high, may be placed under the 8-inch box with the plants to provide the 12- and 16-inch heights required. The stackable sections are constructed much as described for the sections of the pause table. Uprights to define the jump space must be attached to the ends of the obstacle.

(3) High Jump

This jump may be constructed of PVC pipe or of wooden boards similar to the high jump used in obedience. When constructed of PVC, 1-inch Schedule 40 PVC pipe should be used for the framework. The vertical wall, over which the dogs must jump, is made from two, three or four 4-inch PVC pipes to provide the 8-, 12- and 16-inch jump heights.

The framework is constructed to provide a pair of uprights on each side that serve to hold the 4-foot lengths of 4-inch PVC vertically, one on top of the other. The two sets of uprights are connected

with a cross piece to hold them in the vertical position. Each set also has two short leg supports that extend each direction perpendicular to the width of the cross piece (or the jump) to keep the vertical section from tipping over.

One section of 4-inch pipe used at the bottom must be notched in such a way that when in place with the notch over the bottom support pipe of the framework on both ends, the bottom surface of the pipe rests on the ground. In this way, two 4-inch pipes, one placed on top of the other, result in forming an 8-inch jump.

When the obstacle is adjusted to form an approximate 12-inch jump, an additional section of pipe must be added. The ends of the pipe will be notched to fit the uprights.

For the 16-inch height required for Division III dogs, two additional sections are added (a total of four) to provide 16 inches for the height of the jump.

(4) Log Jump

This jump should be constructed of 10 sections of 4-inch Schedule 40 PVC pipe 3½ to 4 feet long. Ten sections are required in order to provide pyramid stacks of three, six or 10 pipes for Divisions I, II and III, respectively. Maximum heights at the peak when stacked in a pyramid are approximately 7, 10½ and 14 inches, respectively for Divisions I, II and III. Two small cloth tubes, about 2 inches in diameter and filled with sand, are needed to place along the base at the front and back to keep the pyramid in place.

Separate uprights are required to delimit the jumping zone above the jump. Only one on each side is required and this is placed at the center of the stack.

(5) Picket Fence Jump

This jump may be constructed using wooden furring strips, cut to length with a decorative picket top. However the cross member should be placed at the top of the picket to minimize any safety hazards. Furring strips are 1½ inches wide. The picket spacing is approximately equal to the picket width. The top strip will extend beyond the pickets to allow placement on the jump standard. Separate pickets can be made for each height or the minimum height lattice jump can be raised to the appropriate height and could be used for all height divisions. The jump heights are 8, 12 and 16 inches.

(6) Lattice Fence Jump

This jump may be constructed from decorative lattice panels. Thin wall lattice panels are made of ¼-inch slats arranged in a cross-hatched pattern and



are available for purchase at lumber yards. The lattice can be cut to the desired width and height. The lattice will need to be stabilized through attachment to a frame. One-inch furring strips are one option that can make a suitable light-weight frame for lattice. The top strip will extend beyond the lattice width to allow placement on the jump standard. Separate lattice jumps can be made for each height or the minimum height lattice jump can be raised to the appropriate height and could be used for all height divisions. The jump heights are 8, 12 and 16 inches.

(7) Window Jump

Overall dimensions of the panel should be 42 to 48 inches wide with an opening 14 inches wide and 30 inches high. Provisions to adjust the bottom of the opening to 8, 12, and 16 inches for Divisions I, II and III, respectively, must be provided. The panel with the opening may be made of wood or heavy cloth, such as denim or canvas. When made of cloth, a 4-inch heading may be sewn along each of the vertical sides so that the cloth can be held in place by slipping the heading over the uprights. In this case, changes in heights may be made by pushing the cloth panel up or down over the uprights. The PVC framework is constructed exactly the same as that used for the tire (hoop jump) obstacle.

Agility II Non-hurdle Obstacles

(1) Crawl Tunnel

The entire framework of this obstacle must be constructed of Schedule 40 or 80 (thick wall), 1½-inch PVC. Only the cross pieces that support the cloth to form the ceiling of the crawl space may be made from Schedule 40 (thick wall) ¼-inch PVC.

Two base runners, each with four uprights spaced about 24 inches apart, form two sides of the tunnel. The sides are held in a vertical position by cross pieces that connect two uprights located directly across from each other, across the top of the tunnel. These cross pieces are 30 inches long, thus providing an opening into the tunnel that is 30 inches wide and 30 inches high.

To prevent the uprights from being pushed forward or backward, the cross pieces connecting the two sides at the top may be connected at their centers the length of the tunnel by three 24-inch lengths of PVC pipe. The sections of PVC pipe that connect the uprights along the base also are 24 inches long. An alternative way of preventing the uprights from being pushed forward or backward, is to connect the uprights (of each side section) near

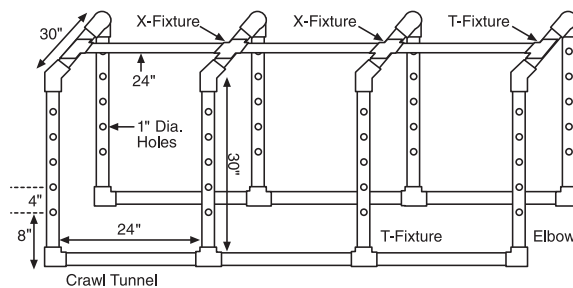

their tops with 24-inch lengths of PVC pipe. This would match the exact pattern of the runner at the base of the uprights.

The uprights have sets of holes drilled through both sides of the pipes to hold cross pieces that support a cloth ceiling under which the dogs must crawl. The hole size depends on the size of the cross piece. The cross pieces are either ½-inch Schedule 40 (thick wall) PVC pipe (actual OD is ¾ inch) with 1-inch hole or ¼-inch steel rod with 5/16-inch hole. Half-inch steel conduit pipe works well. The outside diameter is 5/8 inch. The first, or lowest, set of holes is drilled so that the bottom edge of the holes is 8 inches above ground when the uprights are in place in the fixtures on the base runner. Four additional sets of holes are drilled at 4-inch intervals. This will create crawl spaces of 8, 12, 16 and 20 inches when the PVC

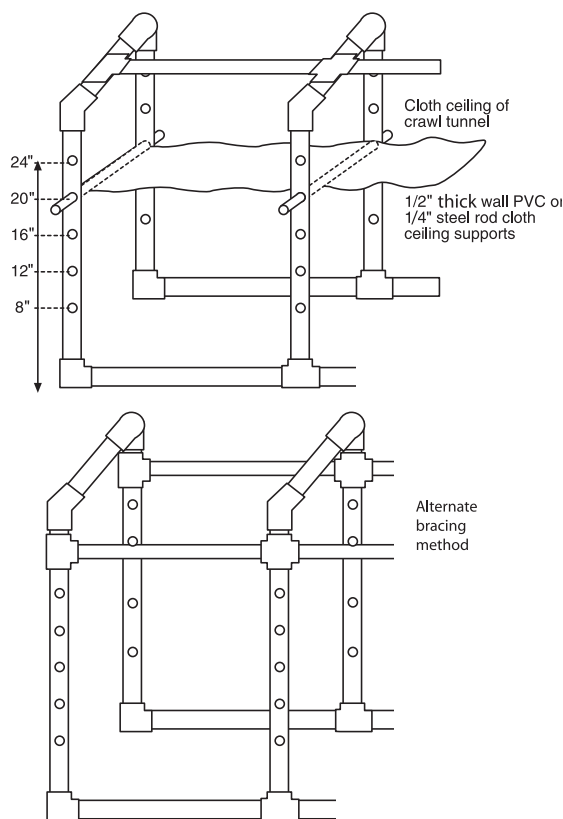



pipe or ¼-inch steel rod cross pieces and cloth are put in place. The cloth is stretched across the tops of the cross pieces to create crawl spaces of different heights.

The cloth, about 30 inches wide, may be fixed in place in various ways. One suggestion is to sew headings in each end, so that when the cross pieces at each end of the obstacle are inserted through the uprights and the headings, the cloth is stretched tight over the two center cross pieces. Stretch-type cloth material is best, because it can be stretched to prevent sagging.

(2) Tire Jump

The tire must be about 30 inches in diameter, and constructed from material, such as black plastic drain pipe, that is at least 3 inches in diameter. It should be painted (or taped) with bands of a contrasting color to provide maximum visibility to the dog.

The supporting framework may be constructed from PVC pipe (1½-inch Schedule 40) or wood. Provisions must be made to adjust the height of the circle so that the inside surface at its lowest point may be set at 8, 12 and 16 inches. The tire may be suspended from the upper cross piece by a cord, while bungee cords or flat elastic bands may be used to hold the tire in place at the sides. The distance between the uprights must be at least 48 inches. The height of the uprights is not critical as long as it is sufficient to suspend the tire at the 16-inch jump height.

When constructed of PVC pipe, the uprights are connected at both the top and bottom by 48-inch cross pieces. The uprights are held vertically in position by 12-inch leg supports that extend forward and backward from the base of the uprights.

This same design for the PVC pipe framework is used for the window jump.

(3) Weave Poles

This obstacle consists of nine PVC poles that are attached to a basal runner or individual holders that are stuck in the ground. The poles are to be 24 inches apart and must flex at the base so that the dog may push the poles sideways as the dog moves through the series of poles.

The base runner is constructed of 1/8-inch-by-1½-inch steel about 17 feet long that may be divided into two or three convenient sections. The base runner may also be constructed using ¼-by-2-inch steel. Two sets of leg braces (12 to 14 inches long) are attached at right angles to each section of the base runner to hold the poles vertically upright. The

surface between the poles must be smooth, without a raised strip of more than ¼ inch high.

Course sequence markers should be placed at least 4 feet to either side of the weave poles so as not to interfere with dog movement.

Single pole holders that have a 5- to 6-inch spike that is stuck in the ground may be used at trials held outdoors. The top of the spike must have a flat steel plate on which a rubber washer and PVC cap to hold the pole are attached.

With either the base runner or the single pole holders, a thick rubber washer and PVC cap (the same size as the PVC poles used) are bolted to the base runner or the steel plate on the single pole holders. Lock-tight nuts should be used on the bolts to prevent the nuts from becoming loose when the poles are inserted and taken out of the caps.

The poles are made from either ½ inch (actually ¾-inch OD) or 1-inch (actually 1⅜-inch OD) Schedule 40 (thick wall) PVC pipe and are 3 to 4 feet high.

(4) Open Tunnel

The specifications for the open tunnel are the same as Agility I.

(5) Swing Plank

This obstacle consists of a wide plank that is suspended at its corners by chains hanging from a metal, PVC, or wooden support structure. The suspended plank is able to swing horizontally in all directions. The dog must place all four feet on the plank while walking over.

The most satisfactory support structure is constructed of 1-inch square steel tubing. There are four L-shaped pieces, two of which are attached at right angles to each side of each end of a 4-foot metal spline. The base of the L-shaped pieces, which are 18 inches long, serve as leg supports to hold the structure in proper position. The upright portions of the L-shaped pieces, which are 15 inches long, serve as the chain supports.

The plank may be made from ¾-inch plywood or constructed as a hollow core plank in the same manner as described for the dog walk. The plank is 4 feet long and about 20 inches wide. The surface of the plank must be painted with a non-skid material. Four chains of suitable length are required to hold the plank about 3 inches above ground. The end links of each end of each chain are cut to form hooks. One end of each chain is hooked to the tip of each upright while the other end is attached to

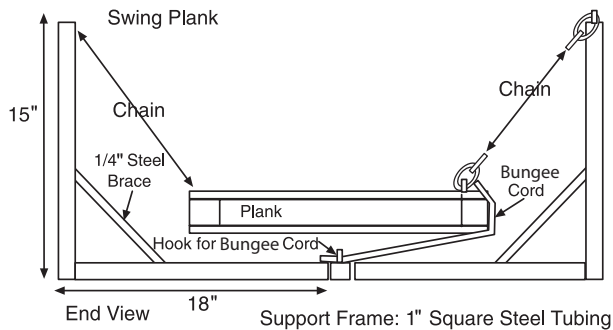

metal brackets at the corners of the plank. The plank is then suspended over the central spline and able to swing in all directions.

A bungee check cord is attached to the two corners of each end of the plank and to the spline about 8 inches from the end. The bungee cord is stretched tightly to prevent the plank from moving too rapidly as the dog moves across it.

(6) Sway Bridge

This obstacle consists of a support structure on which a bridge (similar to a rope bridge of wooden slats) is suspended. Ramps on each end allow the dog to get on and off of the bridge. The dog must move up the entrance ramp and across the bridge, placing all four feet on the bridge, and exit over the off ramp.

The support structure on which the bridge portion is suspended may be constructed of steel (i.e. 1-inch square tubing) or wood. The ends of the bridge are attached to the support structure approximately 18 inches high so that the bridge hangs freely in a shallow arc over the 6-to-8-foot length of the support structure. Entrance and exit ramps, 3 to 4 feet long, lead up to and away from the ends of the bridge. The entirety of each ramp is the contact zone. Paint the ramps the same contrasting color as other contact zones.

The bridge portion is constructed of 2-by-2-inch wooden boards 19 inches long (five pieces may be cut from a standard 8-foot length of 2-by-2-inch board). Holes are drilled through the center of these boards 2 inches from each end. The boards are connected by inserting a cable or a type of rope that does not stretch through the holes of the boards, with 1/2-inch spacers between each board.

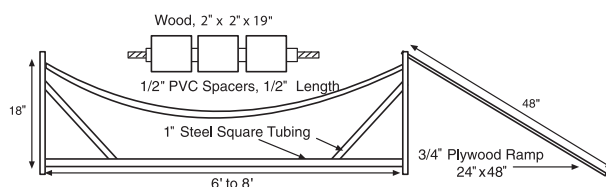

The spacers are necessary to prevent the boards from pinching together as the dog walks across the bridge. Ends of the cable or rope may be attached to the support structure with turnbuckles to ensure that the bridge portion does not have too much slack.

(7) Platform Jump.

This obstacle consists of two low platforms placed with the narrow ends 8, 12 or 16 inches apart and with a jump midway between the two platforms.

The platforms are constructed of wood with surfaces 2 feet wide and 3 to 4 feet long (newly constructed platforms should be made 4 feet long) and 4 inches high. The surfaces are to be painted with a non-skid surface material as described earlier.

The bar jump may be constructed from 1-inch thick-walled PVC pipe. It is made as described for the single bar jump, except that the leg supports are shorter (about 4 inches). This is to allow the jump to tip over easily to help prevent an injury should a dog not make a clean jump. The bar must be non-displaceable to prevent the accidental knock down by a dog's tail. Provisions must be made to adjust the height of the bar to 4, 8 and 12 inches above the surface of the platforms (not the ground) for size Divisions I, II and III, respectively. Each platform is positioned with the 2-foot width next to the jump and at distances of 4, 6 and 8 inches away from the center of the bar (total distances between the platforms are 8, 12 and 16 inches) for size Divisions I, II and III, respectively.

(8) Pause Box

The box should be about 48 inches square. The walls may be constructed of wood or PVC pipe with an overall height of 4 to 6 inches. Four lengths of 4-inch Schedule 40 PVC and four elbows make an excellent box that is lightweight and can be disassembled for storage.

When 4-inch PVC is used, the box may be placed directly on the ground. If 1 1/2- or 2-inch PVC pipe is used, some kind of support must be placed under the box to raise it up to at least 4 inches. Small sand bags, one placed under each corner of the box, work well for this purpose.

Each side of the box should be painted a different color, or with a different number or letter for easy identification of a particular side.



Agility II Jump Obstacles

The specifications for jumps 1- 7, the single bar jump, bush jump, high jump, log jump, picket fence jump, lattice fence jump and window jump, are the same as in Agility I.

(8) Broad Jump

This obstacle should be constructed of 6-inch ($\frac{3}{4}$ inch tolerance) wide wooden boards that are $3\frac{1}{2}$ to 4 feet long. Four uprights to define the space over the jump that the dog must jump, must be placed, one at each corner of the jump. The jump boards can be constructed to allow nesting to facilitate storage. The top boards are mounted on side support boards that result in sloped face to be presented to the dog while jumping. The front edge or low point of the first panel is 1 inch in height and the back edge of the front panel is 3 inches in height. Each panel is progressively 1 inch taller than the preceding panel. This is the same design for the obedience broad jump. (See page 33 of the Kansas 4-H Dog Show Rule Book; Revised January 2010.)

Two boards are used for Division I dogs, three for Division II dogs, and four for Division III dogs. The boards are spaced to create jumping lengths of 16, 24 and 32 inches for Divisions I, II and III, respectively.

Agility III Additional Obstacle

For Agility III, use the specifications of Agility I and Agility II obstacles for construction specifications. Agility III also allows the optional use of one additional obstacle, the cross over walk.

Cross-Over Walk

The cross-over walk consists of a platform with up to four ramps, each about 8 feet long and about 12 inches wide, that can be attached. The ramps shall be securely attached to the sides of a 32-inch-by-32-inch platform set at a height of 36 inches. The obstacle should be rigid, sturdy and balanced in construction, regardless of whether two, three or four ramps are attached. The cross-over walk can have the dog enter on any of the ramps, and is faced with up to three exit choices; right, left or straight across. The handler must give the dog instructions as to the correct choice as per the course layout.

The surface of the ramps and platform will be covered with non-skid material and follow the guidelines as previously described in the dog walk section. The 4-foot contact zones for the ramps of the cross-over walk and dog walk are identical. The ramps of these obstacles could be made to be interchangeable.

The support assembly for the platform could be made of wood legs that could be pinned or hinged (using removable pin hinges). Wooden legs may require some cross-bracing using chain lengths to prevent spreading. Support legs can also be constructed using one-inch diameter pipe attached to the platform table using pipe flanges. The pipe legs can be easily unscrewed and removed for storage.

FINAL ASSEMBLY

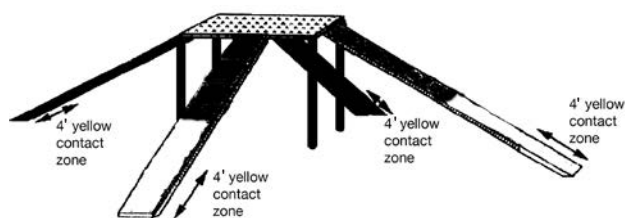

Other Sources of Information

Use Internet Explorer or another Web browser to search for dog agility sites on the Web. Use key phrases such as “dog agility” or “agility equipment” when conducting your search.

Note: Other sources of information may not comply with the Kansas 4-H Agility Dog Show Rule Book.



Icons For Agility Scoresheets

Fixed Score Icons

12' x 3'		
A-FRAME		
<input type="checkbox"/>	<input type="checkbox"/>	PTS 15

16' x 16'		
CROSS-OVER WALK		
<input type="checkbox"/>	<input type="checkbox"/>	PTS 15

8' to 12'		
TEETER-TOTTER		
<input type="checkbox"/>	<input type="checkbox"/>	PTS 15

14'		
SWAY BRIDGE		
<input type="checkbox"/>	<input type="checkbox"/>	PTS 15

12'		
CLOSED TUNNEL		
<input type="checkbox"/>	<input type="checkbox"/>	PTS 15

16'		
WEAVE POLES		
<input type="checkbox"/>	<input type="checkbox"/>	PTS 15

2' x 10'		
PLATFORM JUMP		
<input type="checkbox"/>	<input type="checkbox"/>	PTS 15

4'		
PAUSE BOX		
<input type="checkbox"/>	<input type="checkbox"/>	PTS 15

3' x 23'		
DOG WALK		
<input type="checkbox"/>	<input type="checkbox"/>	PTS 15

12'		
HOOP TUNNEL		
<input type="checkbox"/>	<input type="checkbox"/>	PTS 15

4'		
SWING PLANK		
<input type="checkbox"/>	<input type="checkbox"/>	PTS 15

14'		
OPEN TUNNEL		
<input type="checkbox"/>	<input type="checkbox"/>	PTS 15

6'		
CRAWL TUNNEL		
<input type="checkbox"/>	<input type="checkbox"/>	PTS 15

TIRE JUMP		
<input type="checkbox"/>	<input type="checkbox"/>	PTS 15

3'		
BROAD JUMP		
<input type="checkbox"/>	<input type="checkbox"/>	PTS 10

Variable Score Icons

Agility I

SINGLE BAR JUMP		
<input type="checkbox"/>	<input type="checkbox"/>	PTS 15

BUSH JUMP		
<input type="checkbox"/>	<input type="checkbox"/>	PTS 15

HIGH JUMP		
<input type="checkbox"/>	<input type="checkbox"/>	PTS 15

PICKET FENCE JUMP		
<input type="checkbox"/>	<input type="checkbox"/>	PTS 15

WINDOW JUMP		
<input type="checkbox"/>	<input type="checkbox"/>	PTS 15

LATTICE FENCE JUMP		
<input type="checkbox"/>	<input type="checkbox"/>	PTS 15

2'		
LOG JUMP		
<input type="checkbox"/>	<input type="checkbox"/>	PTS 15

4'		
PAUSE TABLE		
<input type="checkbox"/>	<input type="checkbox"/>	PTS 20

Agility II or III

SINGLE BAR JUMP		
<input type="checkbox"/>	<input type="checkbox"/>	PTS 10

BUSH JUMP		
<input type="checkbox"/>	<input type="checkbox"/>	PTS 10

HIGH JUMP		
<input type="checkbox"/>	<input type="checkbox"/>	PTS 10

PICKET FENCE JUMP		
<input type="checkbox"/>	<input type="checkbox"/>	PTS 10

WINDOW JUMP		
<input type="checkbox"/>	<input type="checkbox"/>	PTS 10

LATTICE FENCE JUMP		
<input type="checkbox"/>	<input type="checkbox"/>	PTS 10

2'		
LOG JUMP		
<input type="checkbox"/>	<input type="checkbox"/>	PTS 10

4'		
PAUSE TABLE		
<input type="checkbox"/>	<input type="checkbox"/>	PTS 15

Kansas 4-H Agility Scoresheet

Team Armband Number: _____	
4-Her's Name: _____	
Dog's Name: _____	Breed _____

Agility Class:		
I	II	III
Height Division:		
1	2	3

Placing
Purple-190-200
Blue-170-189.5
Red-150-169.5
White-149.5 and less

Course Time: _____
Running Time: _____
Time Faults: _____

Running Faults: _____
Other Faults: _____
Additional Faults: _____
Time Faults: _____
TOTAL FAULTS: _____

Location: _____ Date: _____

Judge's Signature: _____

Course Value: 200
Total Faults: _____
FINAL SCORE: _____

Course Layout

Agility I Sample Course

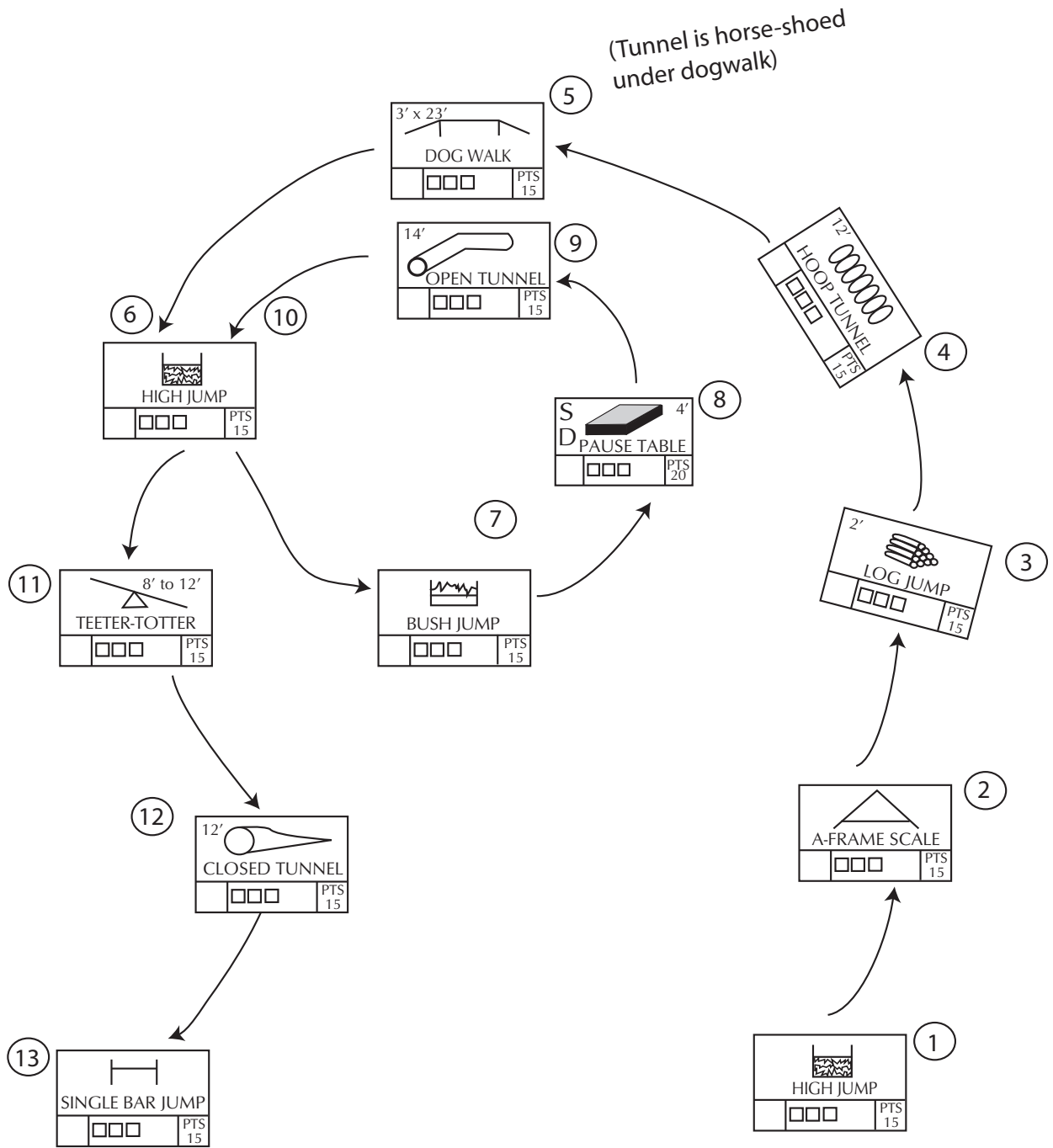

Agility II Sample Course

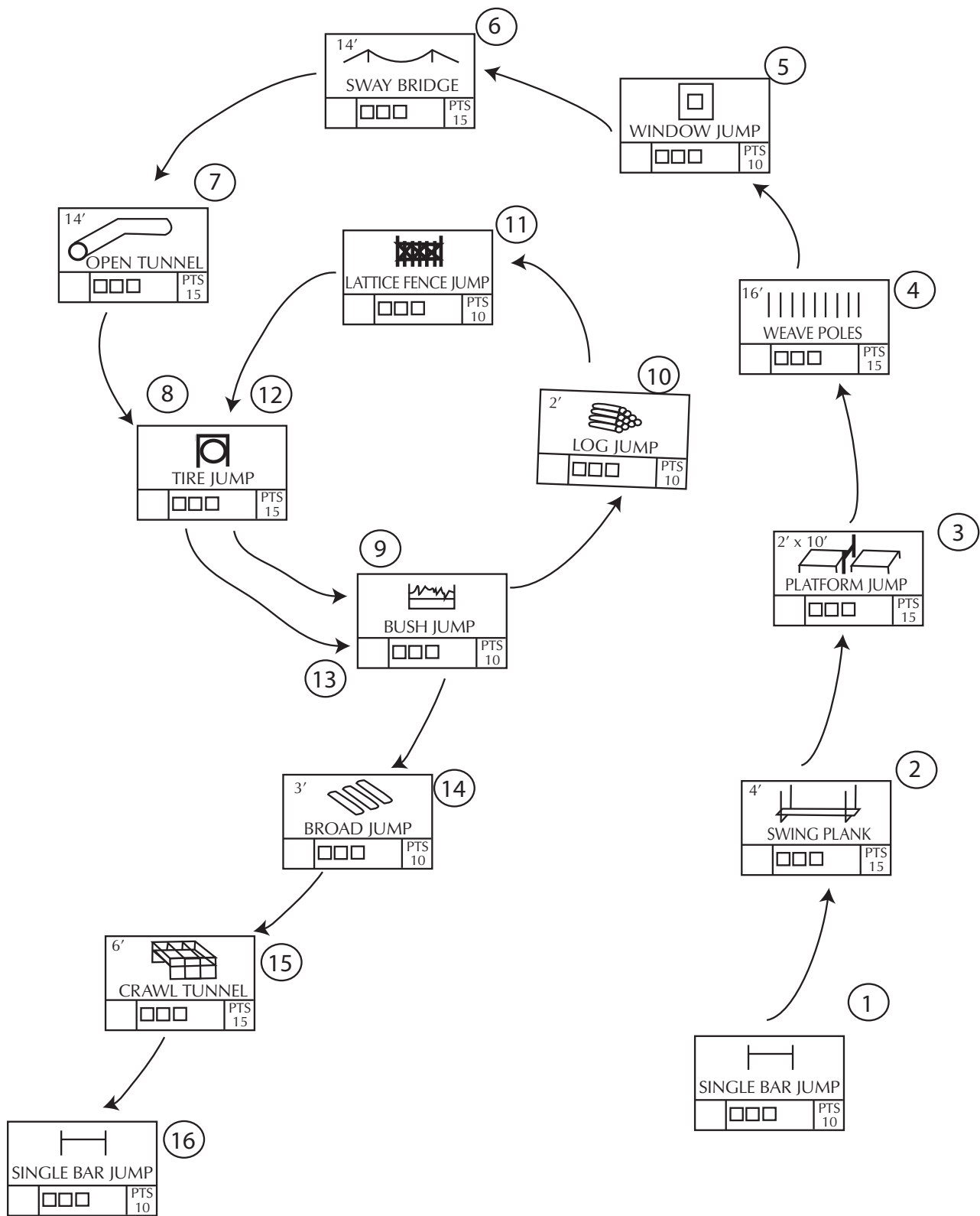

Agility III Sample Course

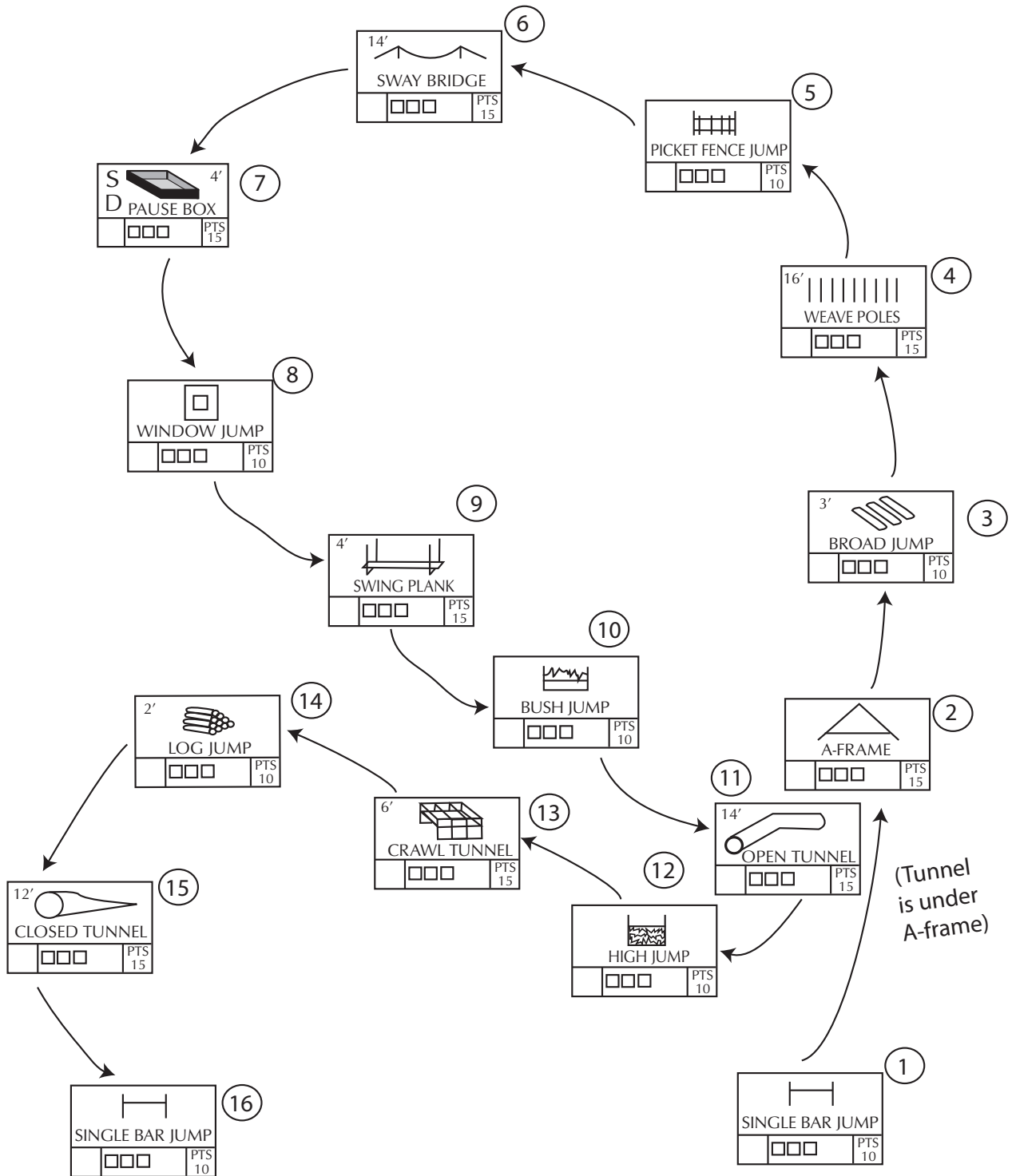

This handbook was prepared by the State 4-H Dog Care and Training Project Action Team. Special acknowledgment is given to Charles W. Kramer for use of his material and contributions to the sport of dog agility, and to Keith Neuway for his continuous review and training coordination. Recognition is also given to Susan Keller and Richard Benjes for their help in revising this book. Coordinated by James P. Adams, associate professor and 4-H Youth Development specialist.

Brand names appearing in this publication are for product identification purposes only.
No endorsement is intended, nor is criticism implied of similar products not mentioned.
Publications from Kansas State University are available at: www.bookstore.ksre.ksu.edu

Date shown is that of publication or last revision. Contents of this publication may be freely reproduced for educational purposes.

All other rights reserved.

In each case, credit James P. Adams, *Agility Dog Show Rule Book*, Kansas State University, March 2012.

Kansas State University Agricultural Experiment Station and Cooperative Extension Service

S-124 (Revised)

March 2012

K-State Research and Extension is an equal opportunity provider and employer. Issued in furtherance of Cooperative Extension Work, Acts of May 8 and June 30, 1914, as amended. Kansas State University, County Extension Councils, Extension Districts, and United States Department of Agriculture Cooperating, John D. Floros, Director.
